

MATCON[®]

POWDERS, HANDLED.

**POWDER HANDLING
SOLUTIONS FOR PHARMACEUTICALS**

Complete Powder Handling Solutions
with Matcon Cone Valve system.

www.matconibc.com

Designed in UK... Delivered from India

AGLIE AND LEAN POWDER HANDLING FOR ACHIEVING MAXIMUM EFFECIENCY

Matcon specialise in providing efficient and flexible systems for handling of powders, granules and tablets using IBC systems.

We offer a complete range of IBC solutions to pharmaceutical manufacturers worldwide. We have the expertise to interface with other process equipment ensuring the system operates at maximum effectiveness.

Increase Tablet Press Efficiency & Productivity

- Solve Powder Handling Challenges of Blend segregation, ratholing and powder compaction
- Protects Blend Uniformity during Discharge
- Flowability of Sticky Powders
- Controlled Flow

Effecient Handling of >1.5 tonne Batches

- Bin size upto 3500L for larger batches
- Reduce no of bins

Cleaning efficiency

- No crevices or hollow sections
- Lesser cleaning
- Elminiate risk of cross contamination

Total Integration

- Dust Free Transfer
- Seamless Transfer without choking

Automation

- Achieve lights-out factory with AGV/AMR & RFID compatibility
- Optimize manpower requirement
- PAT Tool in Blending

Ease of Operation

- Least possible operator intervention
- Ease of tracking with lesser bin movement

Highest Quality Blend with least number of Blenders

MATCON CONE VALVE IBC SYSTEMS FOR POWDER HANDLING



SECURITY SCREENING

WET MILLING

DRY MILLING

DRY GRANULATION

BIN BLENDER

FEED TO TABLET PRESS

Matcon for Wet Granulation

Contained, complete and faster filling on granulator without blocking and bridging

Matcon for Dry Granulation

Feeding blended powders with Matcon System to homogeneity of blend right till the inlet of roller compactor

Matcon Blender

High capacity Bin Blender of efficient blending for most difficult powders

Matcon for Feeding to Compression

Maintain content uniformity and avoid powder handling challenges in final product

Specialized applications for Matcon

Mention MUPS, etc products prone to powder handling challenges

MATCON CONE VALVE IBC SYSTEMS FOR POWDER HANDLING

Universal Cone Valve Solution (200L to 1500L)

Matcon IBC with Universal Cone Valve

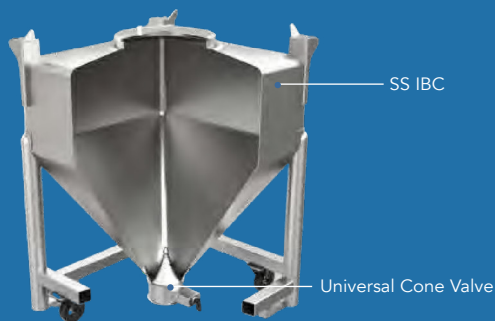

Intergrated Cone Valve Solution (200L to 3500L)

Matcon IBC with Integrated Cone Valve



	Butterfly Valve	Universal Cone Valve	Integrated Cone Valve
Discharge "Free Flowing" Powders	✓	✓	✓
Prevent Rat-holing & Segregation	✗	✓	✓
Full discharge of powder - no waste	✗	✓	✓
Contained powder handling	✗	✓	✓
Overcomes Bridging/Powder Compaction	✗	✗	✓
Handles Sticky/Fluffy/Lumpy Powder	✗	✗	✓
Accurate dosing of powders	✗	✗	✓
Fully automated end-to-end Powder Handling System	✗	✗	✓

MATCON MANUFACTURING FACILITY



Matcon Manufacturing Facility

Matcon local assembly and manufacturing for entire material handling systems of Powder & Tablet Handling IBCs, Cone Valves, Blenders, Discharge station Engineering & project management capabilities to support you in designing and implementation across the project lifecycle Trained resources from Matcon for sales & service across India for immediate assistance



IDEX MPT - Customer Experience Center



Customer Experience Center

RESEARCH



Dedicated Product Trial & FAT Facility

DEVELOP



Testing & Analysis Facility

INNOVATE

 MATCON, Bramley Drive, Vale Park West, Evesham, Worcestershire, WR11 1JH, UK

 +44 (0) 1386 769 000  +44 (0) 870 191 1116

 IDEX India Pvt. Ltd., Plot No. 1039, Sanand GIDC II, Industrial Estate, Ahmedabad - 382 170 Gujarat

 www.idexindia.in  +91 84698 13808  kmahani@idexcorp.com